

# Installation Instructions

## Surface Fixed

Cajón  
Page 1 of 2



### Instrument Components:



Metric Conversion:  
200mm/ 8"  
400mm/ 16"  
450mm/ 18"  
1.5m/ 59"

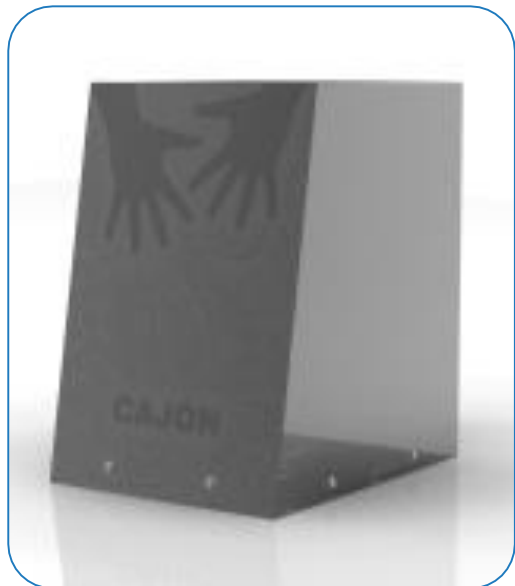
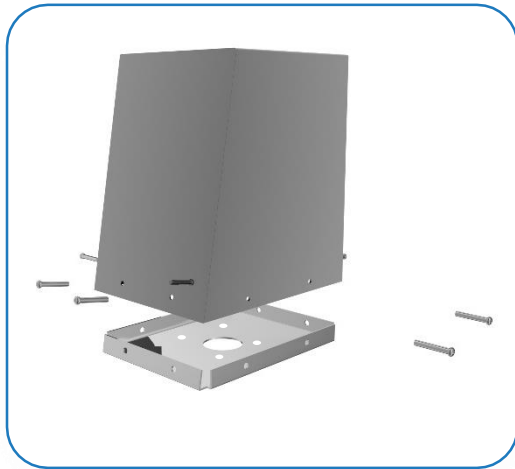

Weight of heaviest part 18kg (Cajón Drum)

1. Locate Instrument in desired location and mark holes to fix to desired surface.

2. Fix to Ground Surface through pre drilled holes in folded base using recommended ground anchors (**Ground Anchors are not supplied**)

3. Attach Cajón to ground fix plate and leg using **M8x25mm security screws** provided using thread lock solution not supplied.

4. Make sure all fixings secure using cover caps provided

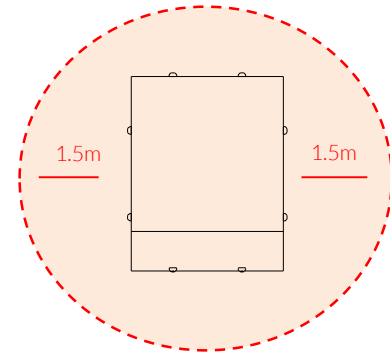

Install Instrument with 1.5m free space (from widest point) around it.

**CAUTION:** Drum surface can get hot in direct sunlight, if possible install in shaded areas.

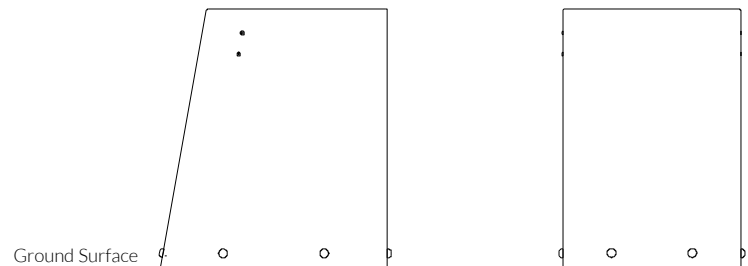

Played with hands

Surface Fix Components:



**Ground Anchors not supplied**

Spares available from [www.musical-play.com](http://www.musical-play.com) or from your local distributor

20 Kg

# Assembly Guide Cajón



## Surface Fixed

Cajón  
Page 2 of 2



### Instrument Components:





x8  
M8x25mm Pin Torx

**CAUTION:** Drum surface can get hot in direct sunlight, if possible install in shaded areas.

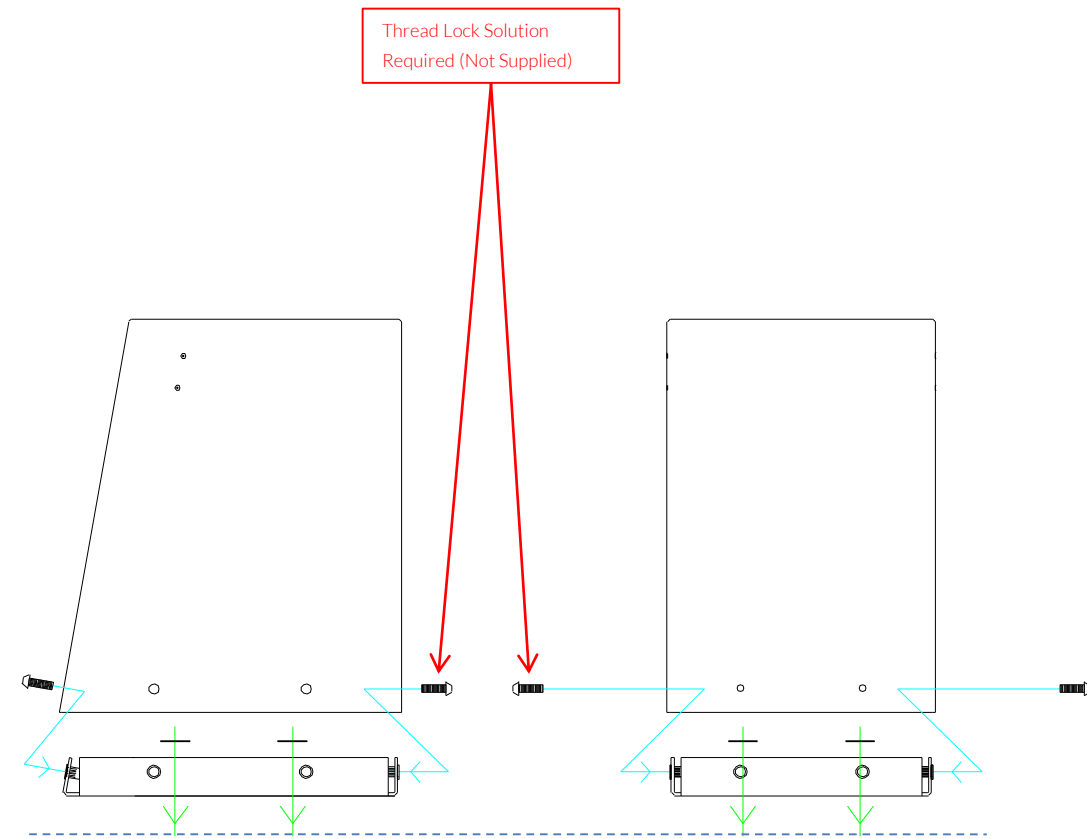
Thread Lock Solution Required (Not Supplied)



### COMPONENTS LIST:

-  M8x25 Pin torx X8
-  M10x30 washer X4

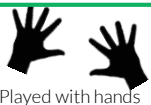

Played with hands

Surface Fix Components:



x4  
M10 Washers

Ground Anchors  
not supplied

Spares available from  
[www.musical-play.com](http://www.musical-play.com) or  
from your local distributor

20 Kg