

# Installation Instructions

## Ground Fixed Calypso Quatro Post Page 1 of 3



### Instrument Components:

-  x8  
M6x20 Security Screw
-  x2  
M6 Saddle Strap
-  x4  
M6 Square Nut
-  x2  
Beater Holder

Metric Conversion:  
250mm/ 10"  
400mm/ 16"  
450mm/ 18"  
1510mm/ 59"  
1.5m/ 59"

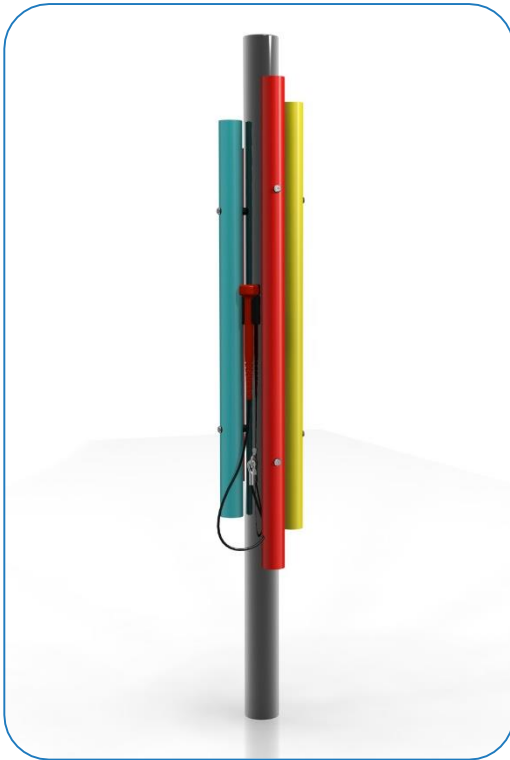

Weight of heaviest part 7.5kg



1. Instrument will arrive on site fully assembled. **(1.1)**  
**(See Assembly Guide)**

2. Attach Ground Fixing studs holes in base of centre post **(1.2)** **(See Ground Fix Post Installation Sheet)**

3. Excavate **1 hole** for the Steel legs **250mm diameter** by **450mm deep** in desired location upon decision from customer.

4. Locate (lower) leg into hole, making sure it is vertical and level prior to concreting in place.

5. Once happy with location of the Instrument, **fill** holes using rapid hardening **concrete**. Be sure to compact concrete around legs and leave to dry according to manufactures guidelines.

6. Attach the 1 pair of beater to the saddle strap on each side of the post. **(1.3)**

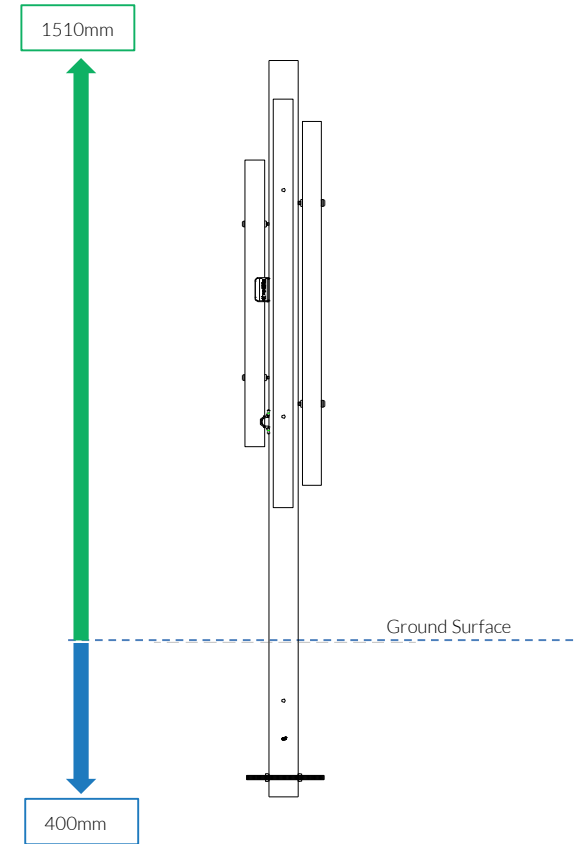
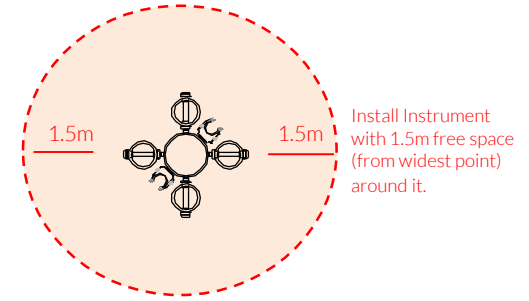

Pair Small Red Beaters X1

### Ground Fix Components:

-  x2  
M10x200 Bolt
-  x4  
M10 Nut

Spares available from [www.musical-play.com](http://www.musical-play.com) or from your local distributor

12 Kg

# Assembly Guide PPCALQU



Tools:



x1  
TX 30 Driver Bit

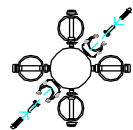

## Ground Fixed Calypso Quatro Post Page 2 of 3



### Instrument Components:





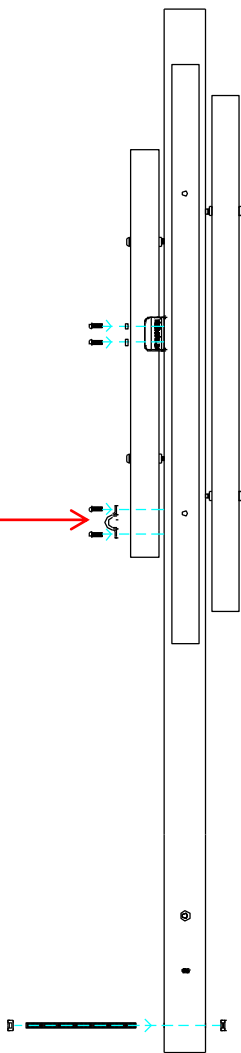

-  x8  
M6x20 Security Screw
-  x2  
M6 Saddle Strap
-  x4  
M6 Square Nut
-  x2  
Beater Holder

Thread Lock Solution  
Required (Not Supplied)

Thread Lock Solution  
Required (Not Supplied)



### COMPONENTS LIST:

-  M10 Nut X4
-  M10x200 Threaded Bar X2
-  Saddle Strap X2
-  M6x20 Pin torx X8
-  M6 Square Nut X2
-  Beater Holder X2



Pair Small Red  
Beaters X1

### Ground Fix Components:

-  x2  
M10x200 Bolt
-  x4  
M10 Nut

Spares available from  
[www.musical-play.com](http://www.musical-play.com) or  
from your local distributor

12 Kg

# Ground Fix Post Installation



Ground Fixed  
Calypso Quatro Post  
Page 3 of 3



## Components:



Metric Conversion:  
50mm/ 2"  
250mm/ 10"  
350mm/ 14"  
400mm/ 16"  
450mm/ 18"

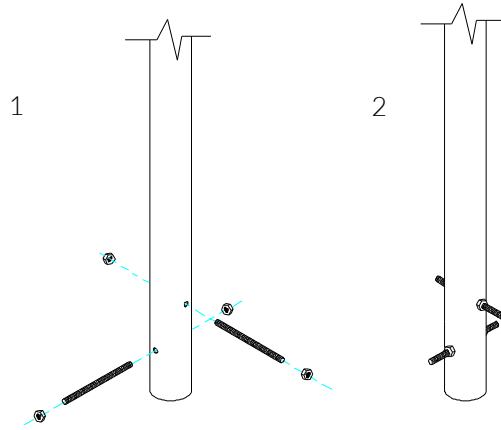

Fix M10x 200 Threaded bar  
in place using M10 Nuts

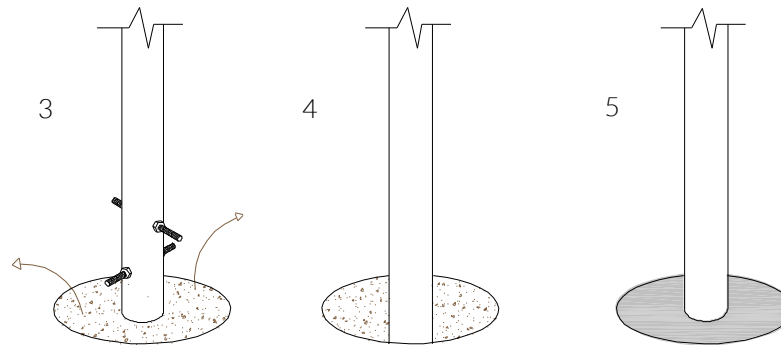

Excavate 1 holes with a  
250mm diameter tapering  
down to 350mm diameter  
and 450mm depth

Compact base of hole with  
50mm of aggregate.  
Lower ground Fix post  
into hole (check  
instrument straight and  
level before filling with  
concrete)

Fix hole with fast drying  
concrete to manufacturers  
specifications.

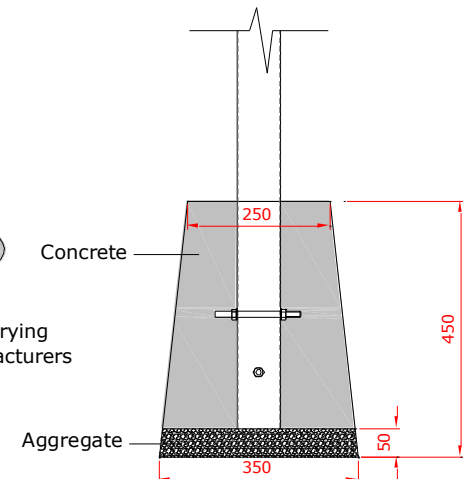

400mm min depth