

Installation Instructions

Surface Fixed

Cavatina
Page 1 of 3

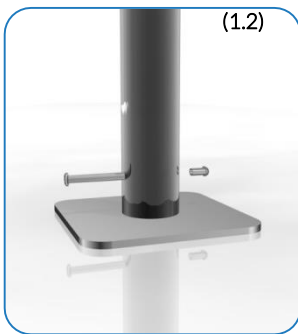
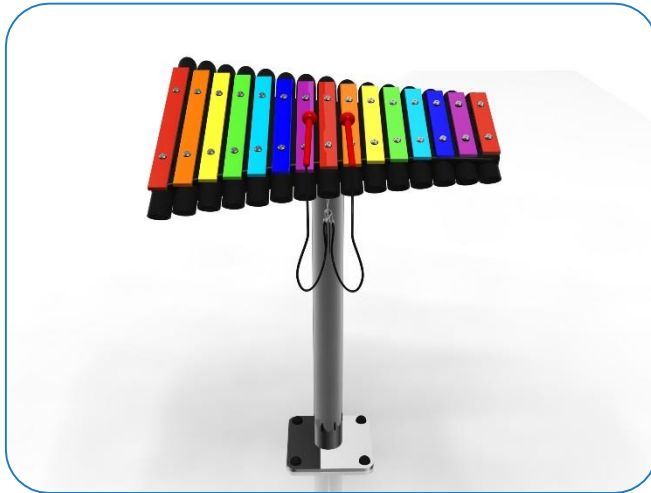

Weight of heaviest part **25kg** (Cavatina)

1. Attach the steel legs to the base of the instrument with the M8 Nyloc Nuts and 2 part security caps. **(1.1)** (See Assembly Guide)

2. Attach Surface Fixing posts to legs **(1.2)** (See Ground Fix Post Installation Sheet)

3. **Locate Plate** in desired location and mark holes to fix to desired surface.

4. Fix to Surface using recommended ground anchors not supplied

5. Make sure all fixings are covered and secure using cover caps provided

6. Attach the 1 pair of beater to the saddle strap on the leg. **(1.3)**

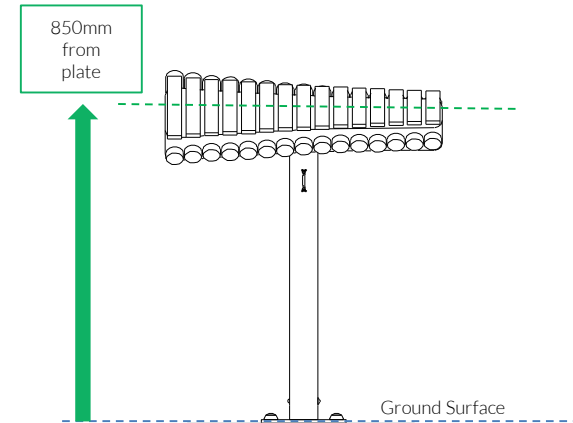
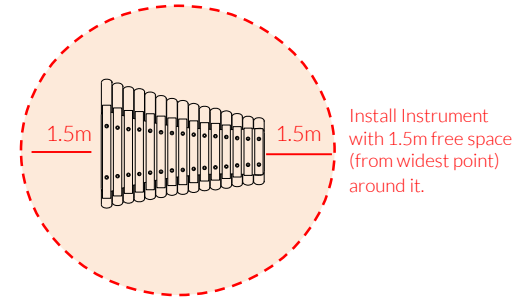

Instrument Components:



x4

M8 Nyloc Nut



x2

M6x20 Security Screw



x4

2 Part Cover Cap

Cap



x1

M6 Saddle Strap

Metric

Conversion:

250mm/ 10"

300mm/ 12"

450mm/ 18"

700mm/ 28"

850mm/ 33"

1.5m/ 59"



Pair Small Red Beaters X1

Surface Fix Components:



x1

M10x70 Security Screw



x1

M10 Barrel Nut



x4

2 Part Cover Cap

Ground Anchors not supplied



Spares available from www.musical-play.com or from your local distributor

30 Kg

Assembly Guide PPCAVA



Tools:



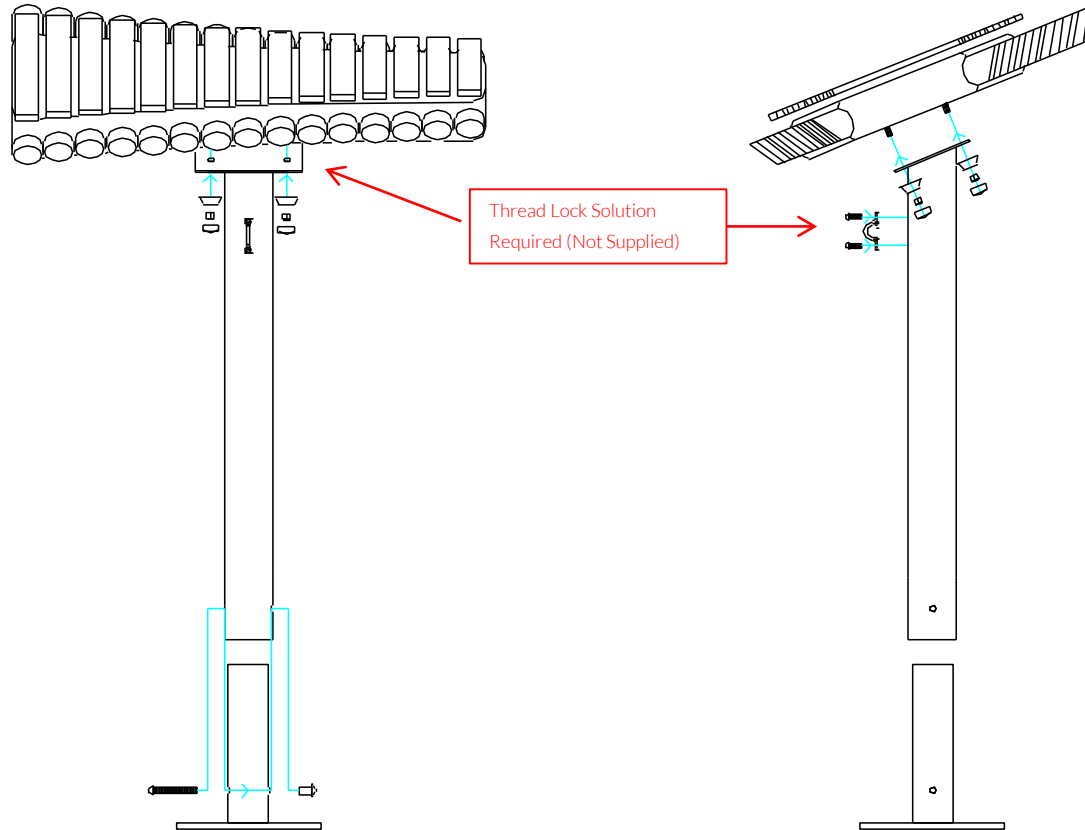

 x1
  x1
 TX 30 Driver Bit TX 40 Driver Bit

Surface Fixed

Cavatina
Page 2 of 3



COMPONENTS LIST:

-  2 Part Cover Cap X8
-  M8 Nyloc nut X4
-  Saddle Strap X1
-  M6x20 Pin torx X2
-  M10x70 Pin torx X1
-  M10 Barrel Nut Pin torx X1

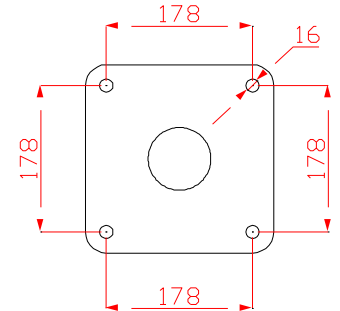

Instrument Components:



-  x4
M8 Nyloc Nut
-  x2
M6x20 Security Screw
-  x4
2 Part Cover Cap
-  x1
Cap
-  x1
M6 Saddle Strap

Thread Lock Solution
Required (Not Supplied)



Pair Small Red Beaters X1

Surface Fix Components:

-  x1
M10x70 Security Screw
-  x1
M10 Barrel Nut
-  x4
2 Part Cover Cap

Ground Anchors
not supplied

Spares available from
www.musical-play.com or
from your local distributor

30Kg

Surface Fix Post Installation

Tools:

 x2
TX 45 Driver Bit

Surface Fixed

Cavatina
Page 3 of 3



Components:



x1

M10 Barrel Nut



x1

M10x70 Security Screw



x4

2 Part Cover Cap

Thread Lock Solution
Required (Not Supplied)

Metric
Conversion:
50mm/ 2"
250mm/ 10"
350mm/ 14"
400mm/ 16"
450mm/ 18"

1

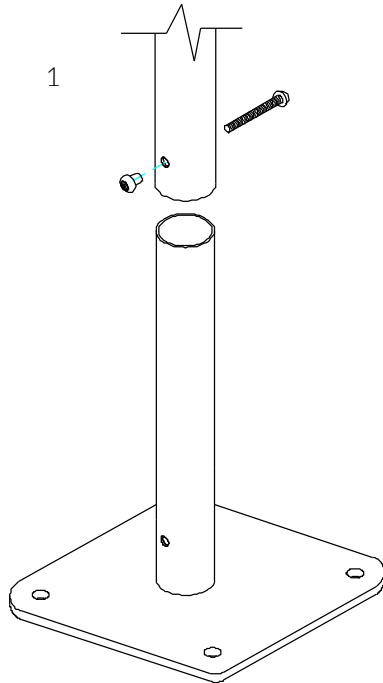

Locate the Surface fix Plate into the leg of the instrument.

2

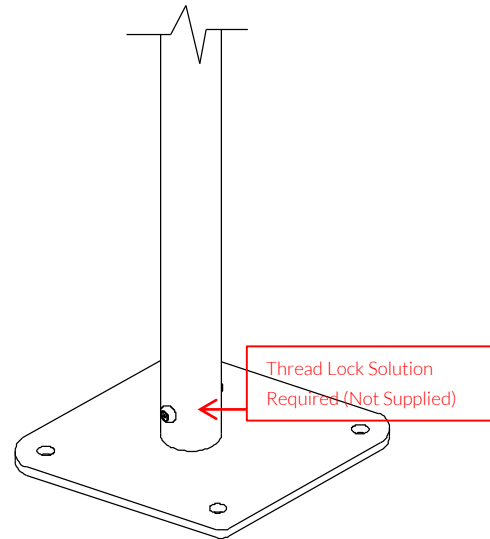

Fix instrument to Surface fix plate using M10 bolt and Barrel Nut and use **thread locking solution** to prevent fixings working loose.

3

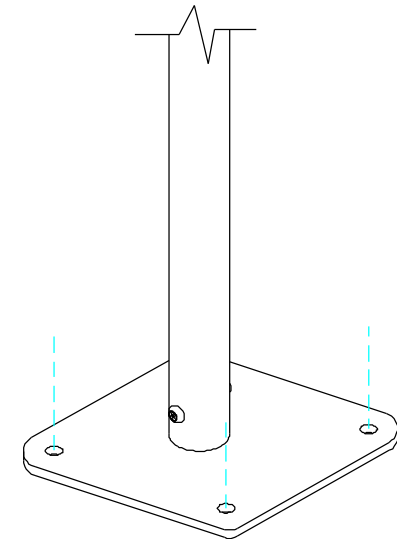

Fix Surface Plate to the ground surface **Ground Anchors Not provided** cover fixings with caps provided