

Installation Instructions

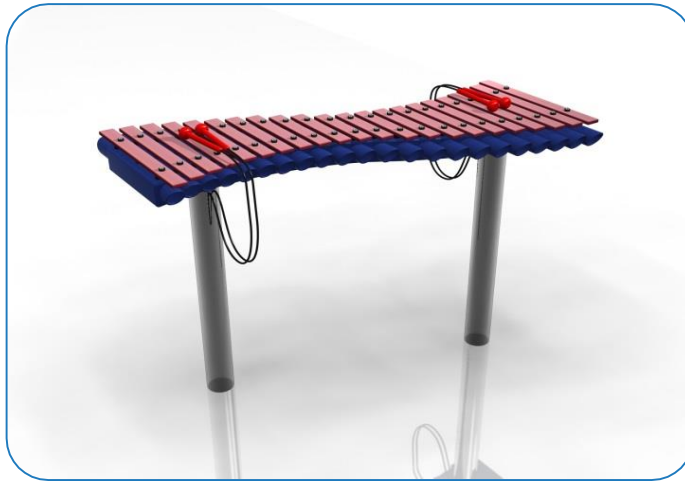

1. Attach the steel legs to the base of the instrument with the M8 Nyloc Nuts and 2 part security caps. **(1.1)** (See Assembly Guide)

2. Attach Surface Fixing posts to legs **(1.2)** (See Ground Fix Post Installation Sheet)

3. **Locate Plate** in desired location and mark holes to fix to desired surface.

4. Fix to Surface using recommended ground anchors not supplied

5. Make sure all fixings are covered and secure using cover caps provided

6. Attach the 1 pair of beater to the saddle strap on each leg. **(1.3)**

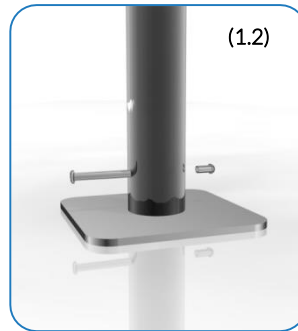
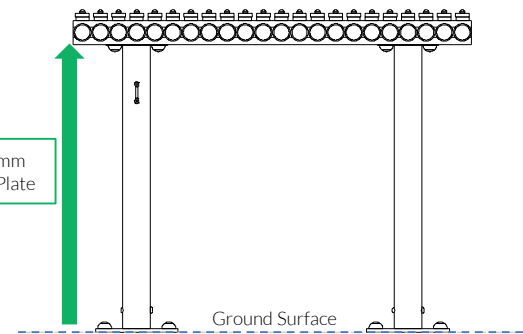
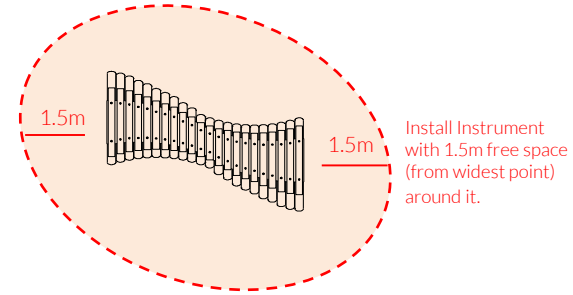

Weight of heaviest part **14kg** (Duo)

Surface Fixed

Duo
Page 1 of 3



Instrument Components:



-  x8
M8 Nyloc Nut
-  x4
M6x20 Security Screw
-  x8
2 Part Cover Cap
-  x2
M6 Saddle Strap

Metric Conversion:
178mm/ 7"
232mm/ 9"
750mm/ 29 1/2"
850mm/ 33"
1.5m/ 59"



Pair Small Red Beaters X2

Surface Fix Components:

-  x2
-  x2
-  x8

Ground Anchors not supplied

Spares available from www.musical-play.com or from your local distributor

28 Kg

Assembly Guide PDDUO

Tools:

- x1
- x2

Surface Fixed

Duo
Page 2 of 3



Instrument Components:

- x8
- x4
- x8
- x2
- x2

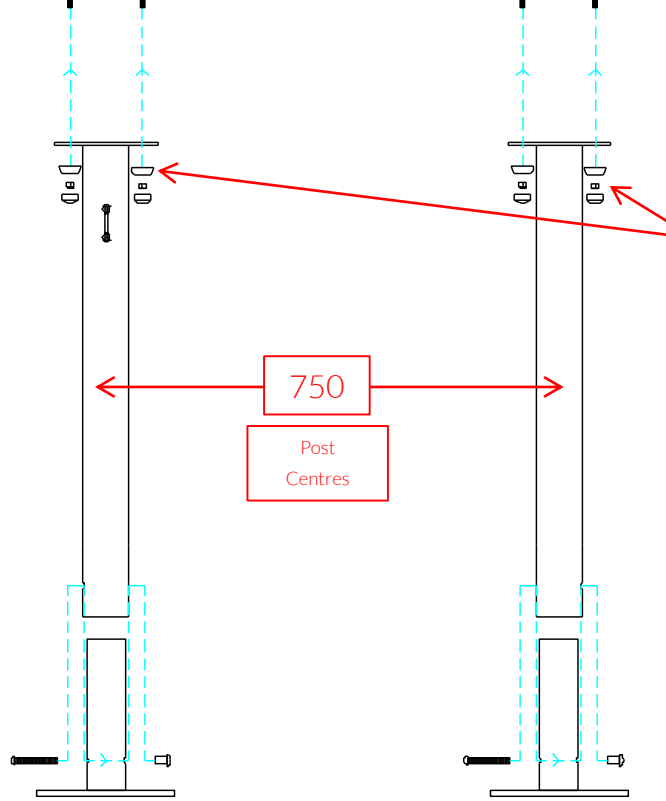
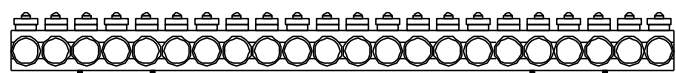

PPDUO FRONT

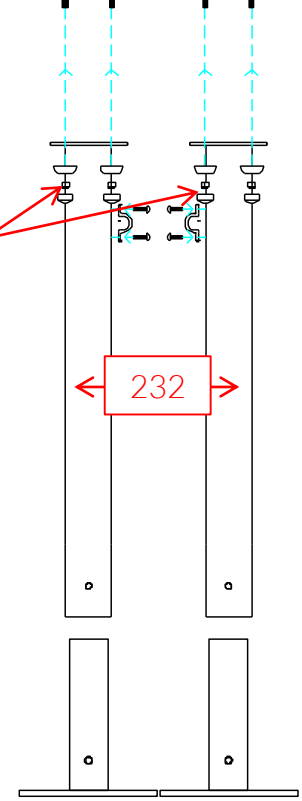
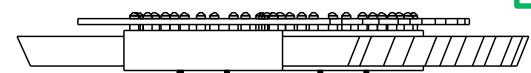

PPDUO SIDE

COMPONENTS LIST:

- 2 Part Cover Cap X8
- M8 Nyloc nut X8
- M10 Nut X8
- M10x200 Threaded Bar X4
- Saddle Strap X2
- M6x20 Pin torx X4
- M10x70 Pin torx X2
- M10 Barrel Nut Pin torx X2

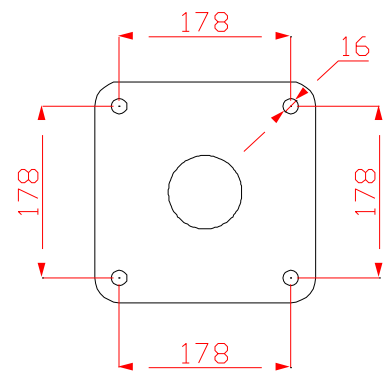

Thread Lock Solution
Required (Not Supplied)

Pair Small Red Beaters X2

Surface Fix Components:

- x2
- x2
- x8

Ground Anchors
not supplied

Spares available from
www.musical-play.com or
from your local distributor

28 Kg

Surface Fix Post Installation

Tools:

 x2
TX 45 Driver Bit

Surface Fixed

Duo
Page 3 of 3

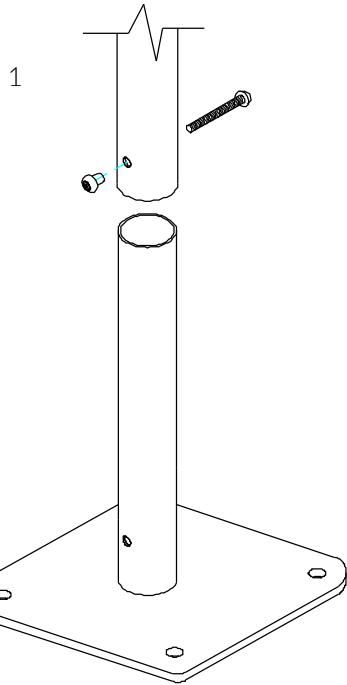

Locate the Surface fix Plate into the leg of the instrument.

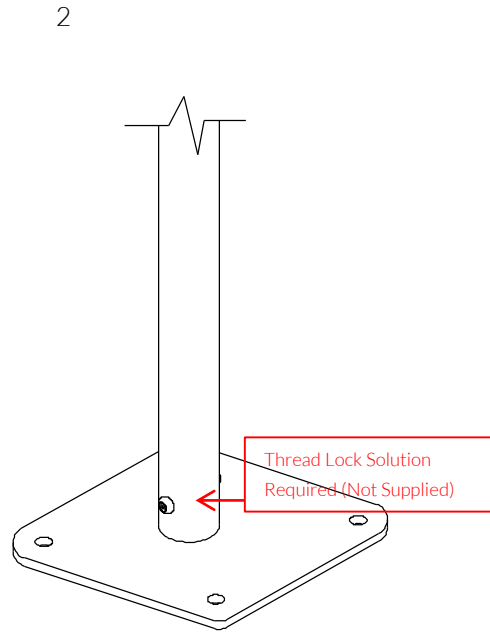

Fix instrument to Surface fix plate using M10 bolt and Barrel Nut and use **thread locking solution** to prevent fixings working loose.

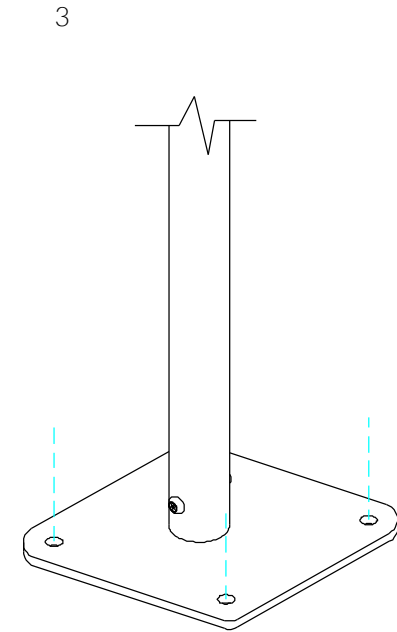

Fix Surface Plate to the ground surface **Ground Anchors Not provided** cover fixings with caps provided

Components:



x2

M10 Barrel Nut



x2

M10x70 Security Screw



x8

2 Part Cover Cap

Thread Lock Solution
Required (Not Supplied)