

Installation Instructions

Surface Fixed

Handpipes
Page 1 of 3

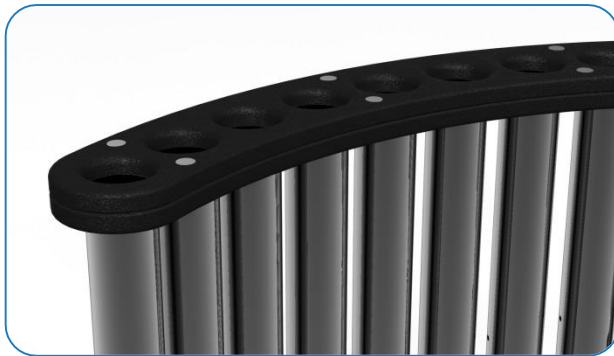

Weight of heaviest part **20kg** (Handpipes)

1. Handpipes will arrive on site assembled, Surface Fixings will need to be installed **(1.1)** (See Assembly Guide)

2. Attach Surface Fixing posts to legs (See Surface Fix Post Installation Sheet)

3. Locate Instrument in desired location and mark holes to fix to desired surface.

4. Fix to Surface using recommended ground anchors not supplied

5. Make sure all fixings are covered and secure using cover caps provided

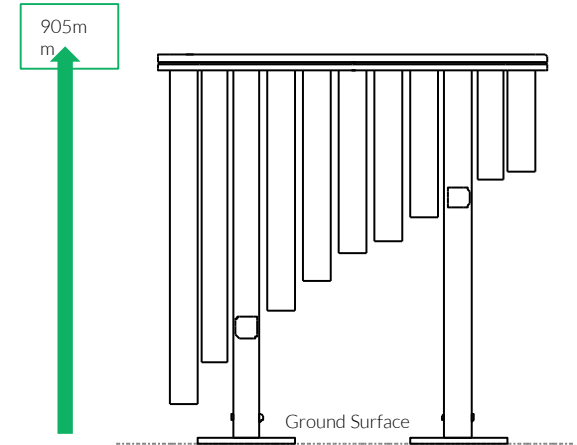
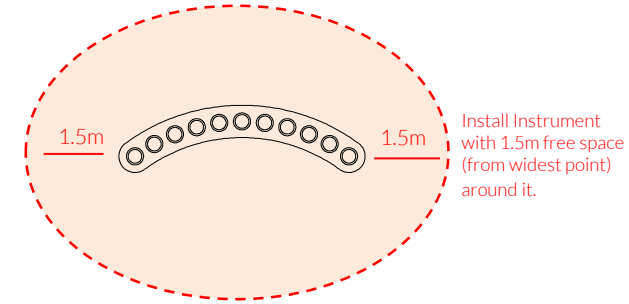

Surface Fix Components:

M10x50 Security Screw x2
M10 Barrel Nut x2
2 Part Cover Cap x8

Ground Anchors not supplied

Spares available from www.musical-play.com or from your local distributor

25 Kg

Assembly Guide PPHAND

Surface Fixed

Handpipes
Page 2 of 3



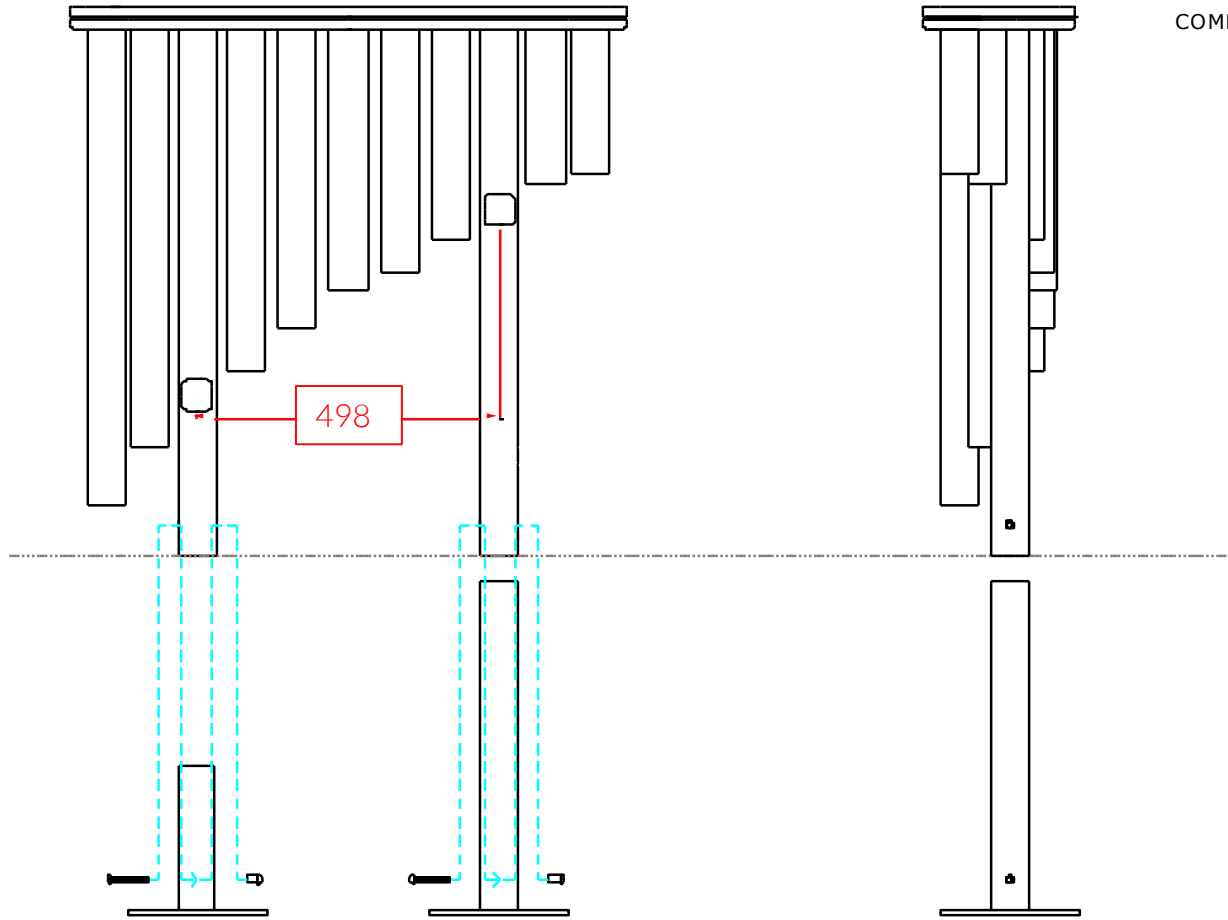

Instrument
Components:

Instrument assembled



COMPONENTS LIST:

-  M10x50 Security Screw X2
-  M10 Barrel Nut X2

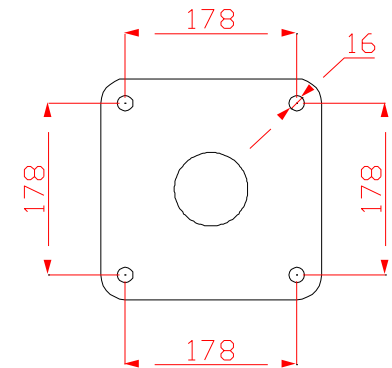



Thread Lock Solution
Required (Not Supplied)



Played with hands

Surface Fix
Components:

-  x2
-  x2
-  x8

Ground Anchors
not supplied

Spares available from
www.musical-play.com or
from your local distributor

25 Kg

Surface Fix Post Installation

Tools:

 x2
TX 45 Driver Bit

Surface Fixed

Handpipes
Page 3 of 3



Components:

 x2

M10 Barrel Nut

 x2

M10x50 Security Screw

 x8

2 Part Cover Cap

Thread Lock Solution
Required (Not Supplied)

Metric
Conversion:
50mm/ 2"
250mm/ 10"
350mm/ 14"
400mm/ 16"
450mm/ 18"

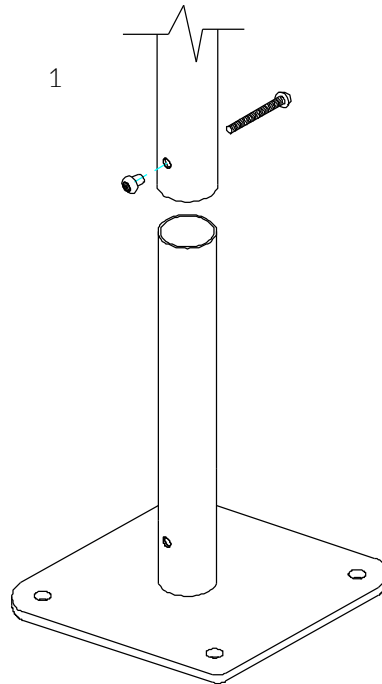

1
Locate the Surface fix Plate into the leg of the instrument.

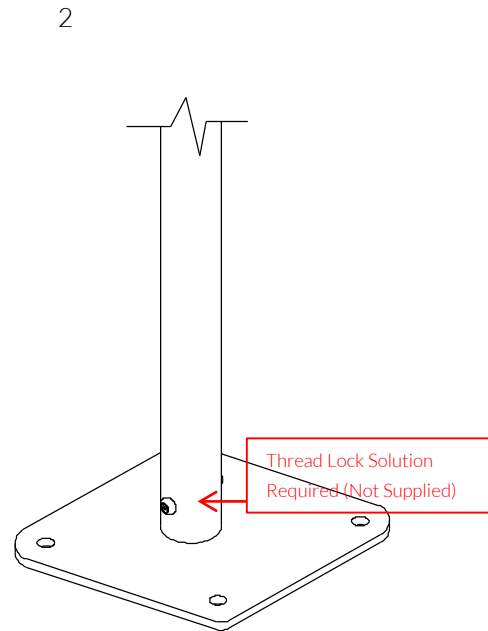

2
Fix instrument to Surface fix plate using M10 bolt and Barrel Nut and use **thread locking solution** to prevent fixings working loose.

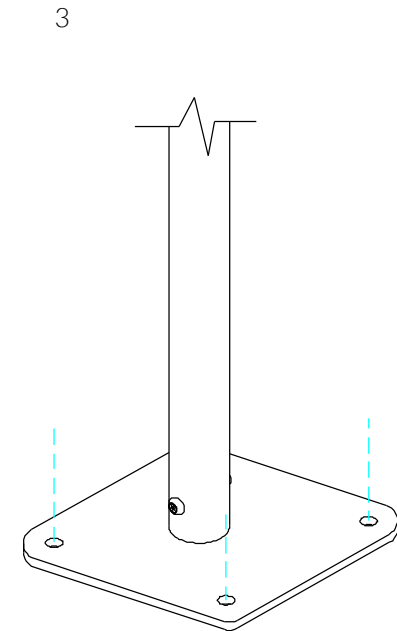

3
Fix Surface Plate to the ground surface **Ground Anchors Not provided** cover fixings with caps provided

Repeat Parts 1-3 for both legs