

Installation Instructions

Ground Fixed Rainbow Trio Bongos Page 1 of 3



Instrument Components:



x6

M10x50 Security Screw



x6

M10x50x3 Square washer



x4

PU 200 Mount



x2

PU 250 Mount

Metric Conversion:
250mm/ 10"
850mm/ 33"
1.5m/ 59"

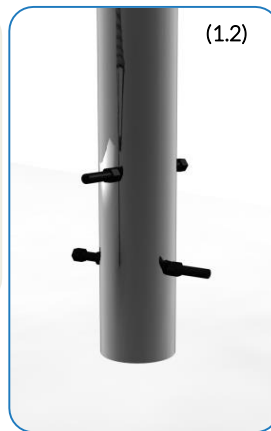
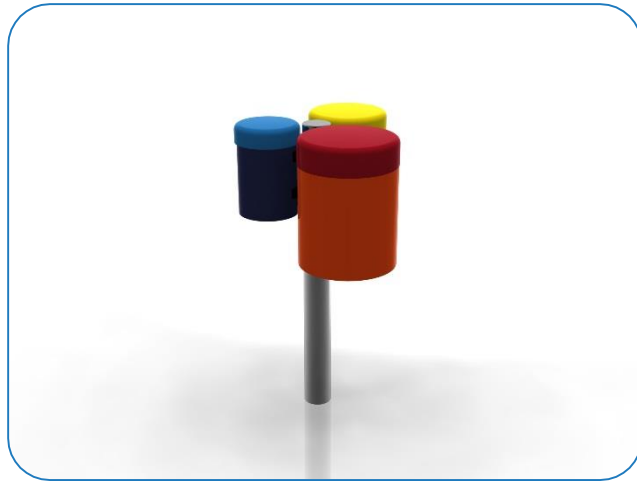

Weight of heaviest part 4.5kg (Large drum Medium Congas)

1. Attach the steel leg to each of the bongos with the M10x50 security screws, square washers and PU mounts. (1.1) (See Assembly Guide)

2. Attach Ground Fixings to legs (1.2) (See Ground Fix Post Installation Sheet)

3. Excavate 1 hole for the Steel leg 250mm diameter by 300mm deep, in desired location upon decision from customer.

4. Locate (lower) leg into hole making sure they are vertical and level prior to concreting in place.

5. Once happy with location of the Instrument, fill hole using rapid hardening concrete. Be sure to compact concrete around legs and leave to dry according to manufactures guidelines.

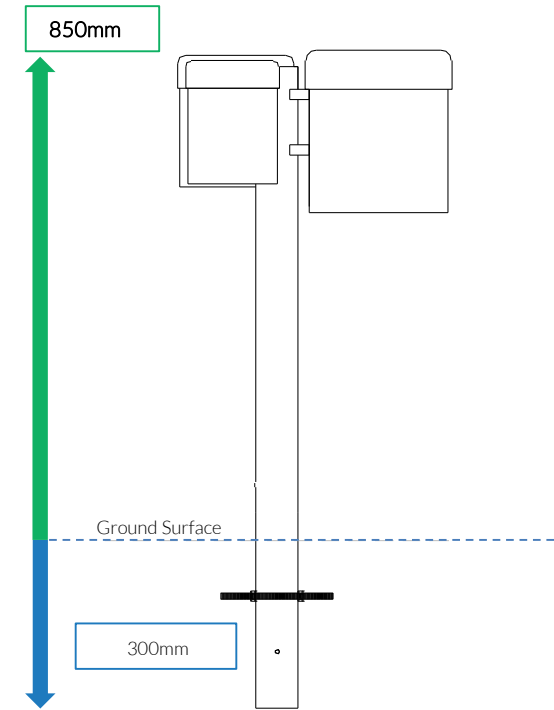
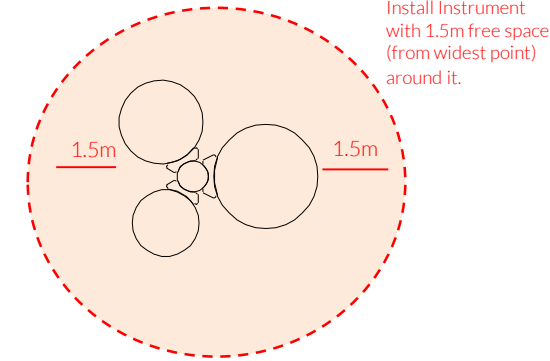

Played with hands

Ground Fix Components:



x2

M10x200 Bolt



x4

M10 Nut

Spares available from
www.musical-play.com or
from your local distributor

15 Kg







Assembly Guide PPRTBON



Tools:

-  x1
- TX 45 Driver Bit

COMPONENTS LIST:

-  M10x50 Pin torx X6
-  M10x50x3 square washer X6
-  HDPE MOUNT 200 X4
-  HDPE MOUNT 250 X2
-  M10 Nut X4
-  M10x200 Threaded Bar X2

Thread Lock Solution
Required (Not Supplied)



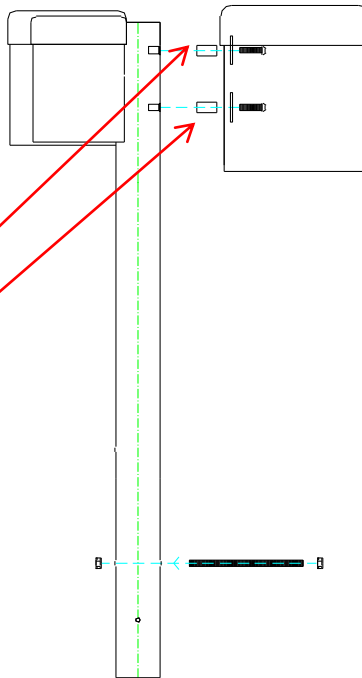
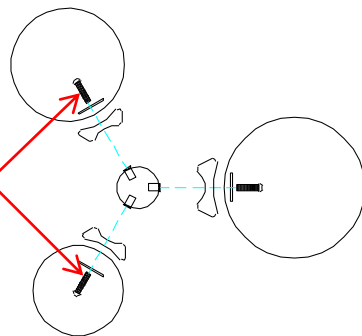

Thread Lock Solution
Required (Not Supplied)



PPRTBON FRONT

Ground Fixed
Rainbow Trio Bongos
Page 2 of 3



-  x6
- M10x50 Security Screw
-  x6
- M10x50x3 Square washer
-  x4
- PU 200 Mount
-  x2
- PU 250 Mount

Thread Lock Solution
Required (Not Supplied)



Ground Fix
Components:

-  x2
- M10x200 Bolt
-  x4
- M10 Nut

Spares available from
www.musical-play.com or
from your local distributor

14.8 Kg
15 Kg
20 Kg

Ground Fix Post Installation

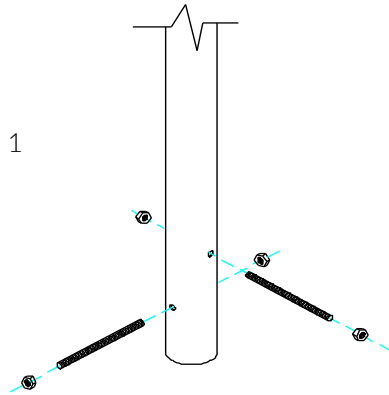

1
Insert M10x 200 Threaded bar into pre drilled holes in Ground Fixing Post

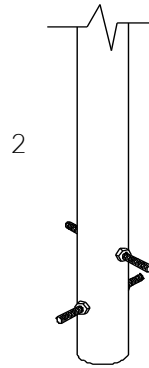

2
Fix M10x 200 Threaded bar in place using M10 Nuts

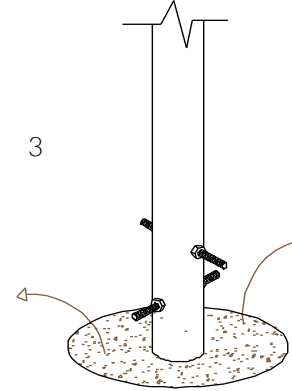

3
Excavate a hole with a 250mm diameter tapering down to 350mm diameter and 350mm depth

Foundations should not present a hazard. These foundations are recommended as a guide, for more information on foundation details for various surface see Part 1 of BS EN 1176.

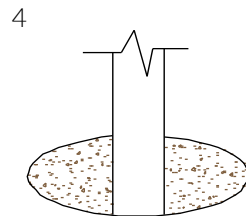

4
Compact base of hole with 50mm of aggregate. Lower ground Fix post attached of instrument into hole (check instrument straight and level before filling with concrete)

300mm min depth

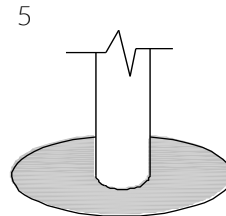

5
Fill hole with fast drying concrete to manufacturers specifications.

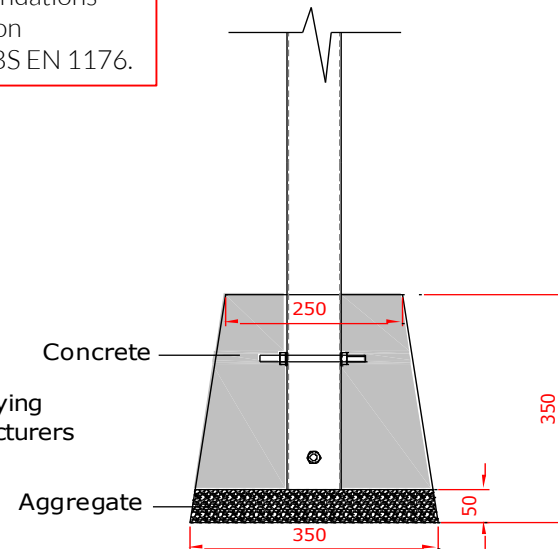

Components:



x2

M10x200 Bolt



x4

Metric Conversion:
50mm/ 2"
250mm/ 10"
350mm/ 14"

Installation Instructions

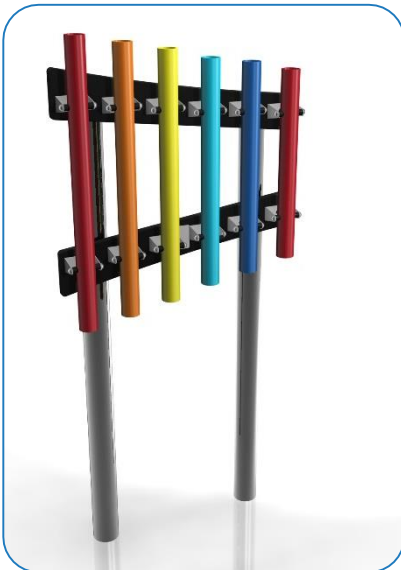

1. Carefully lay 2 x legs on a level surface and check distance between legs is equal. Line up pre drilled holes in the backboards with the holes in legs and ensure the instrument is aligned square with the legs. Fix in place using M8x40mm screws supplied (see installation guide)

2. Attach Ground Fixings to base of legs (See Ground Fix Post Installation Sheet)

3. Excavate 2 holes on site of installation minimum 500mm deep (adjust depth according to age range for intended players)

4. Carefully raise the instrument from the ground with legs attached and locate (lower) legs into holes making sure they are vertical and level prior to concreting in place. (See Ground Fix Sheet)

5. Once happy with location and levels, fill holes using rapid hardening concrete. Be sure to compact concrete around legs and leave to dry according to manufactures guidelines

6. Beaters can be fixed to Steel posts with fixings provided

Install Instrument with 1.5m free space (from widest point) around it.

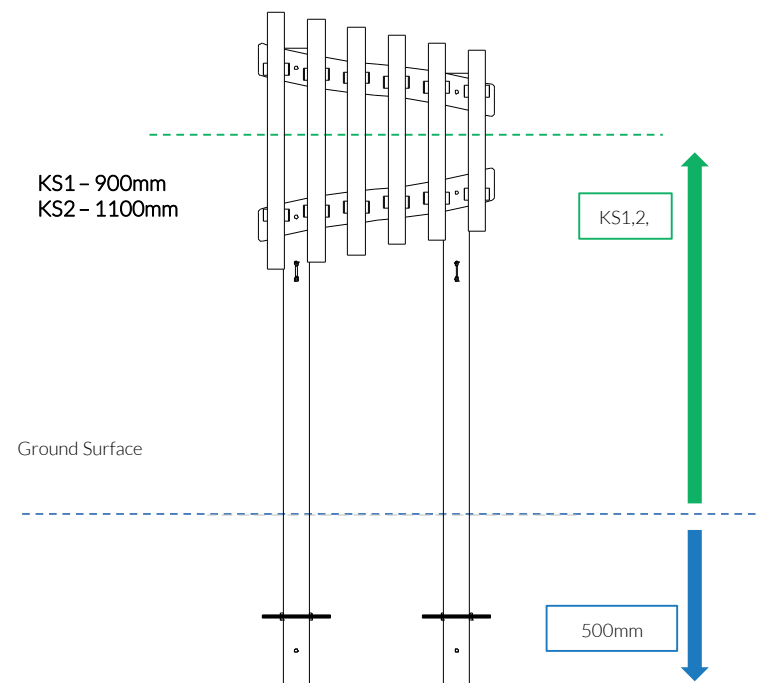
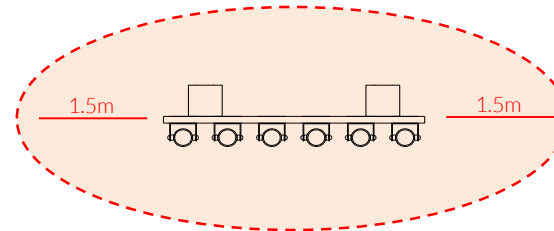

Ground Fixed

Rainbow Trio Chimes
Pentatonic 6 Notes
Page 1 of 4



Metric Conversion:
500mm/ 19 11/16"
900mm/35 7/16"
1100mm/ 43 5/16"
1500mm/ 59 1/16"

Weight of heaviest part 8.35kg (Freechimes)

Components:



Pair Small
Beaters X1

Ground Fix
Components:



x4

M10x200 Threaded Bar



x8

M10 Nut

Spares available from
www.musical-play.com or
from your local distributor

16 Kg

Assembly Guide PPFREC



Ground Fixed

Rainbow Trio Chimes

Pentatonic 6 Notes

Page 2 of 4



Eye Straps
X2







M6x20mm
Secure Screw
X4

M8x40mm
Secure Screw
X4

Tools:

TX 30 Driver Bit x1
TX 40 Driver Bit x1

COMPONENTS LIST:

-  M10 Nut X8
-  M10x200 Threaded Bar X4
-  Saddle Strap X2
-  M6x20 Pin torx X4
-  M8 Lock washer X4
-  M8x40 Pin torx X4

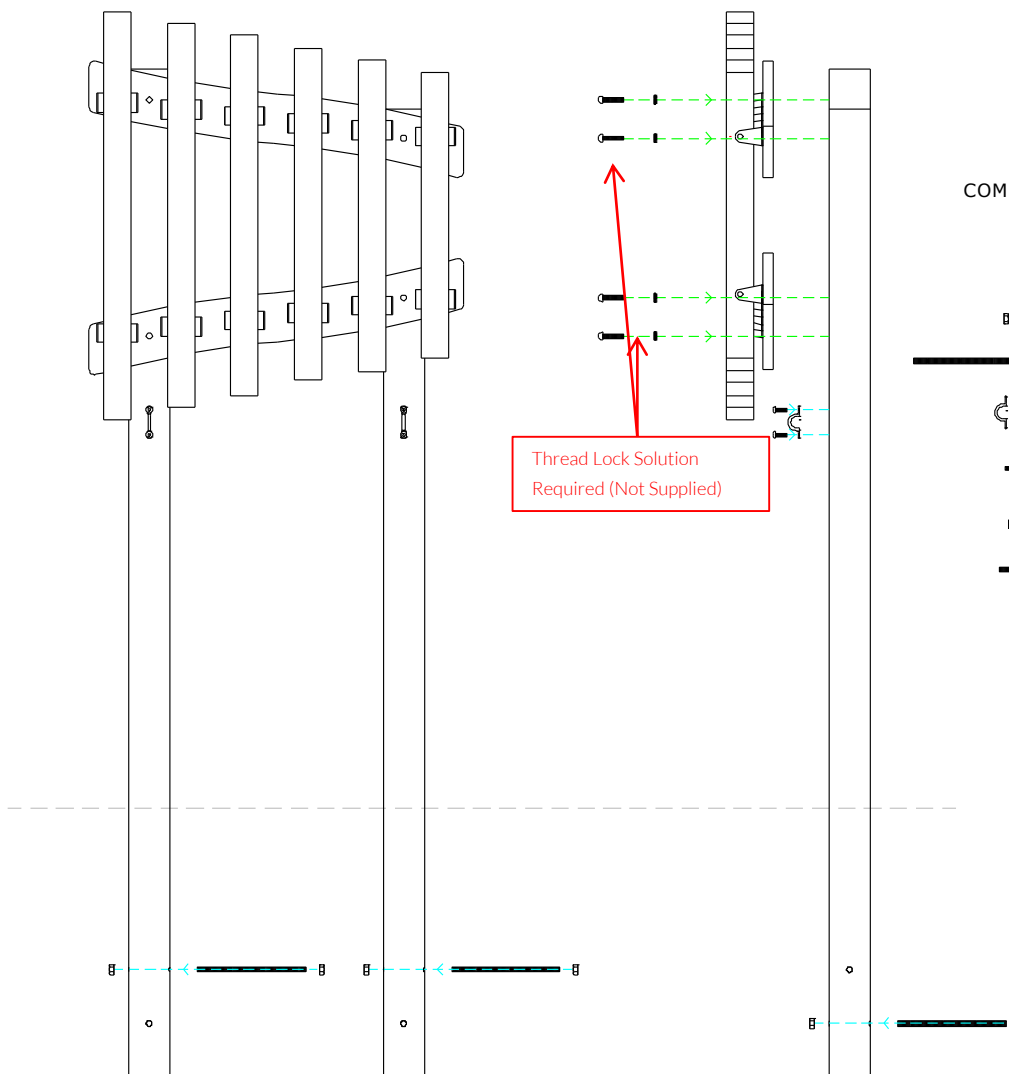



Thread Lock Solution
Required (Not Supplied)

Thread Lock Solution
Required (Not Supplied)



Pair Small
Beaters X1

Ground Fix
Components:

 x4
 x8

Spares available from
www.musical-play.com or
from your local distributor

16 Kg

Ground Fix Post Installation

Foundations should not present a hazard. These foundations are recommended as a guide, for more information on foundation details for various surface see Part 1 of BS EN 1176.



Ground Fixed

Rainbow Trio Chimes
Pentatonic 6 Notes

Page 3 of 4

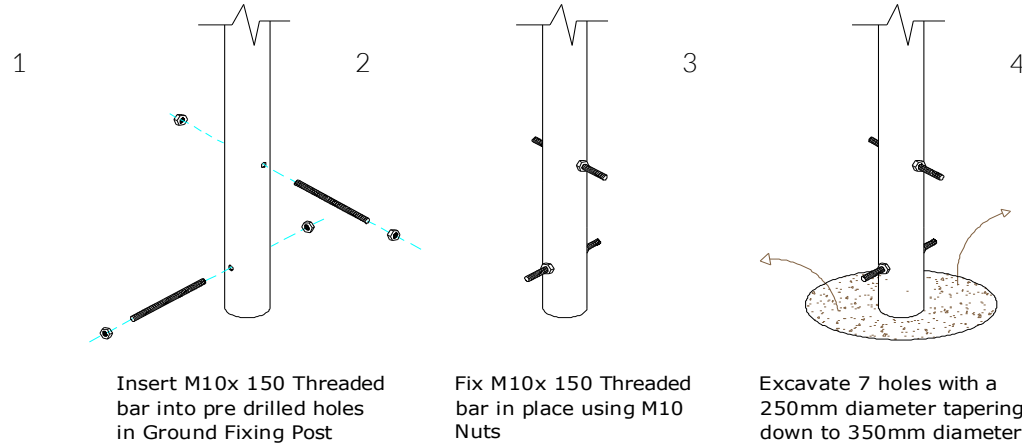

Metric Conversion:
50mm/ 2"
100mm/ 4"
250mm/ 10"
350mm/ 14"
500mm/ 19 11/16"
550mm/ 21 21/32"

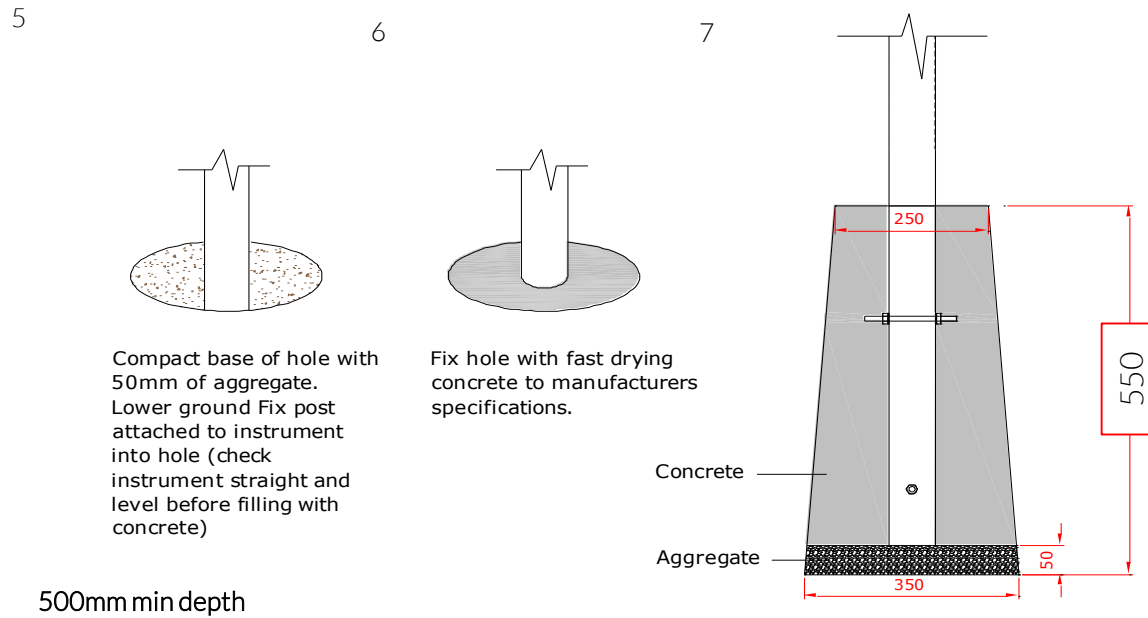

Components:



x4

M10x200 Threaded Bar



x8

M10 BZP Nut

Thread Lock Solution
Required (Not Supplied)

Ground Fix Installation

Ground Fixed

Rainbow Trio Chimes

Pentatonic 6 Notes

Page 4 of 4



472mm Pentatonic 6 Note Post Centres

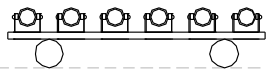

1

Carefully lay 2 x legs on a level surface. Line up pre drilled holes in the backboards with the legs and ensure the instrument is aligned square with the legs. Fix in place using 8x70mm screws supplied

Metric Conversion:

50mm/ 2"
250mm/ 10"
350mm/ 14"
500mm/ 1 ft 7 11/16"
472mm/ 1 ft 6 37/64"
709mm/ 2 ft 3 29/32"

2

Excavate 2 holes with a 250mm diameter tapering down to 350mm diameter and minimum 650mm depth

3

Compact base of hole with 50mm of aggregate. Lower ground Fix posts attached to instrument into hole (check instrument straight and level, and at correct height before filling with concrete)

4

Fill holes with fast drying concrete to manufacturers specifications. If posts protrude above instrument they can be cut down

Minimum installation depth required 650mm, to set height of instrument bury deeper until optimum playing height is achieved.

Foundations should not present a hazard. These foundations are recommended as a guide, for more information on foundation details for various surface see Part 1 of BS EN 1176.

Installation Instructions

Ground Fixed Rainbow Trio Metallophone

Page 1 of 3



Weight of heaviest part 7kg (Metallophone)

1. Attach the steel legs to the base of the instrument with the M8 Nyloc Nuts and 2 part security caps. **(1.1)** (See Assembly Guide)

2. Attach Ground Fixing posts to legs **(1.2)** (See Ground Fix Post Installation Sheet)

3. Excavate 1 hole for the Steel legs **250mm diameter by 350-500mm deep** depending on Key stage, in desired location upon decision from customer.

4. Locate (lower) legs into holes making sure they are vertical and level prior to concreting in place.

5. Once happy with location of the Instrument, **fill holes using rapid hardening concrete.** Be sure to compact concrete around legs and leave to dry according to manufactures guidelines.

6. Attach the 1 pair of beater to the saddle strap on the leg. **(1.3)**

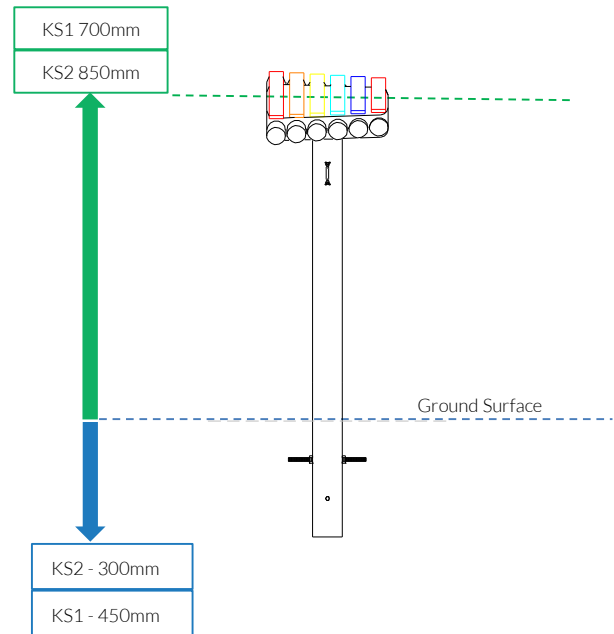
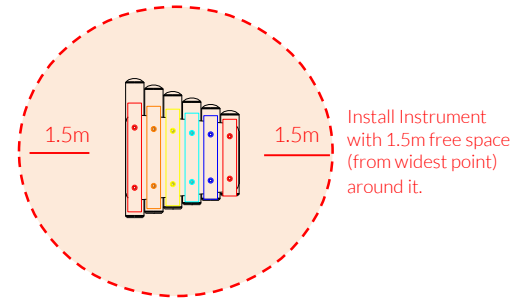

Instrument Components:

-  x4
-  x2
-  x4
-  x1

Metric Conversion:	
250mm/ 10"	
300mm/ 12"	
450mm/ 18"	
700mm/ 28"	
850mm/ 33"	
1.5m/ 59"	



Ground Fix Components:

-  x2
-  x4

Spares available from www.musical-play.com or from your local distributor

19.5 Kg

Assembly Guide PPSANS

Ground Fixed Rainbow Trio Metallophone Page 2 of 3



Instrument Components:

-  x4
M8x20 Security Screw
-  x2
M6x20 Security Screw
-  x4
2 Part Cover
Cap
-  x1
M6 Saddle Strap

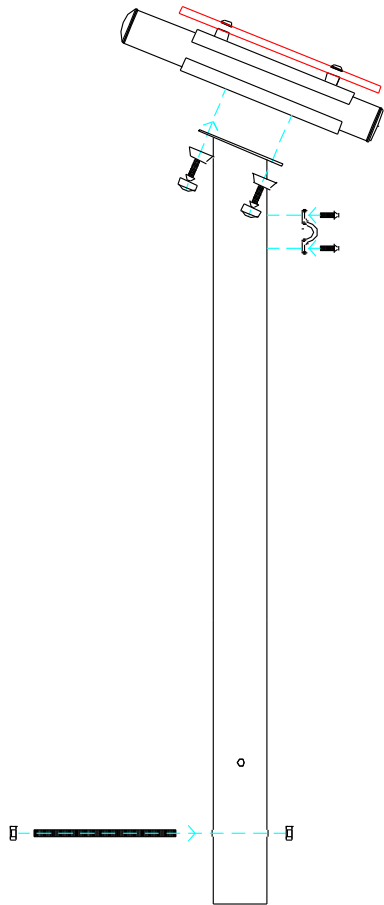

PPRMET SIDE

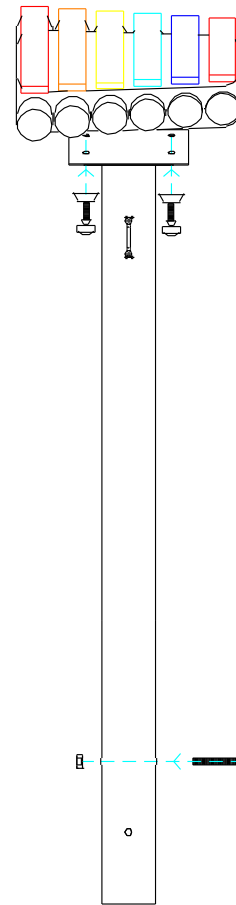







PPRMET FRONT

Tools:

-  x1
-  x1

COMPONENTS LIST:

-  2 Part Cover Cap X4
-  M8x20 Pin torx X4
-  M10 Nut X4
-  M10x200 Threaded Bar X2
-  Saddle Strap X1
-  M6x20 Pin torx X2



Pair Small Red
Beaters X1

Ground Fix Components:

-  x2
-  x4

Spares available from
www.musical-play.com or
from your local distributor

19.5 Kg

Ground Fix Post Installation

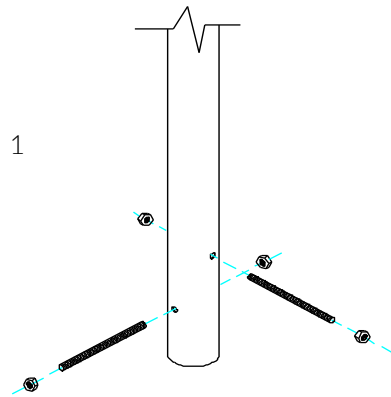

1
Insert M10x 200 Threaded bar into pre drilled holes in Ground Fixing Post

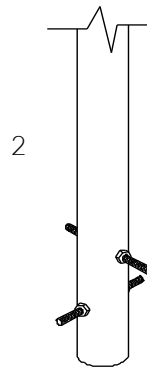

2
Fix M10x 200 Threaded bar in place using M10 Nuts

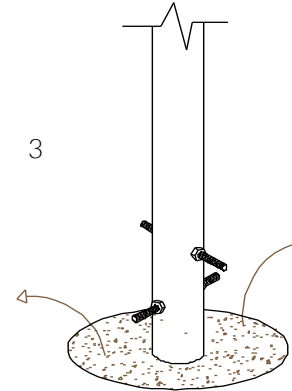

3
Excavate a hole with a 250mm diameter tapering down to 350mm diameter and 350mm depth

Foundations should not present a hazard. These foundations are recommended as a guide, for more information on foundation details for various surface see Part 1 of BS EN 1176.

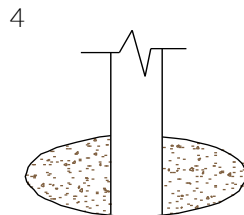

4
Compact base of hole with 50mm of aggregate. Lower ground Fix post attached of instrument into hole (check instrument straight and level before filling with concrete)

300mm min depth

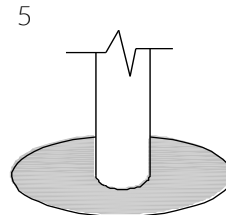

5
Fill hole with fast drying concrete to manufacturers specifications.

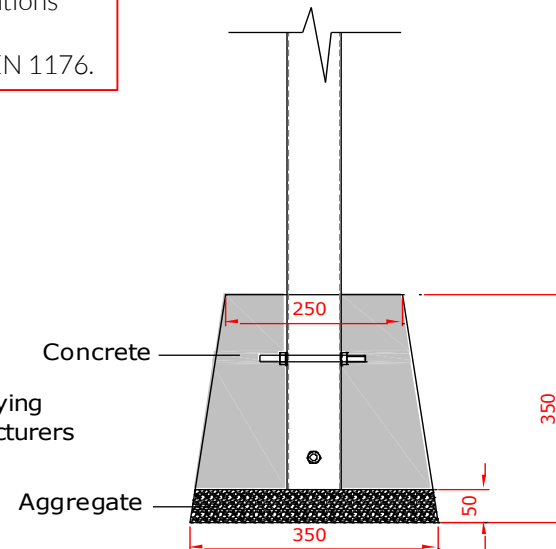

Ground Fixed Rainbow Trio Metallophone Page 3 of 3



Components:

 x2
M10x200 Bolt

 x4
M10 Nut

Metric Conversion:

50mm/ 2"
250mm/ 10"
300mm/ 12"
350mm/ 14"
400mm/ 16"
450mm/ 18"